

PLAN VIEW

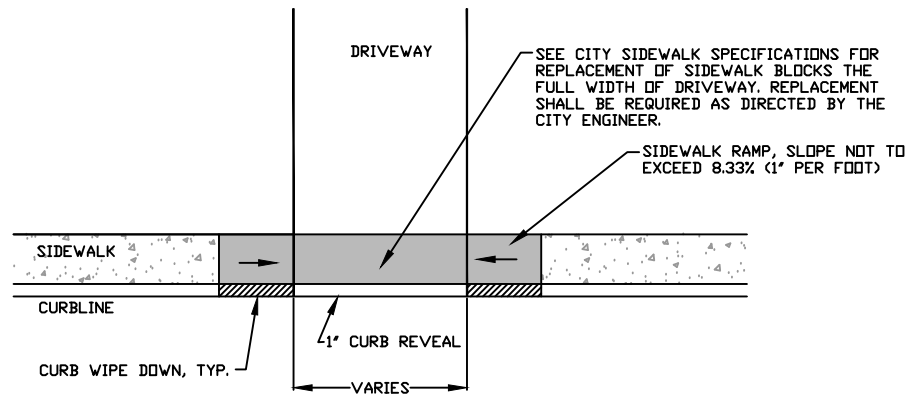

PLAN VIEW

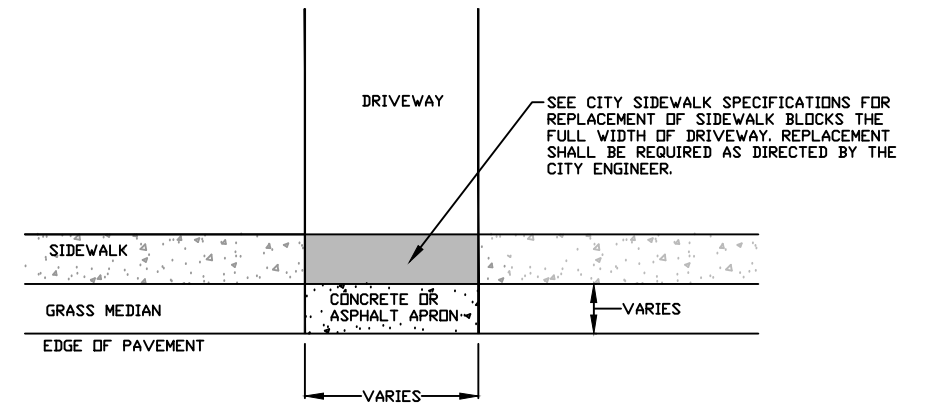

PLAN VIEW

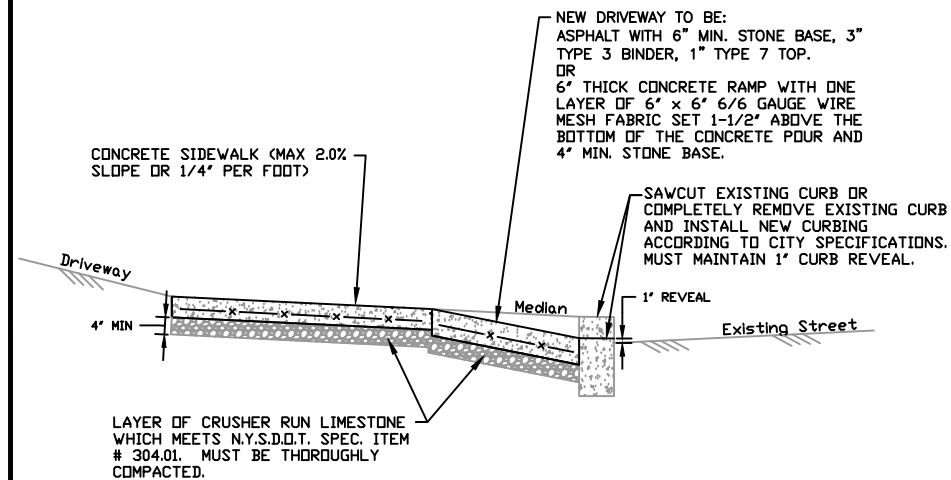

CROSS SECTION

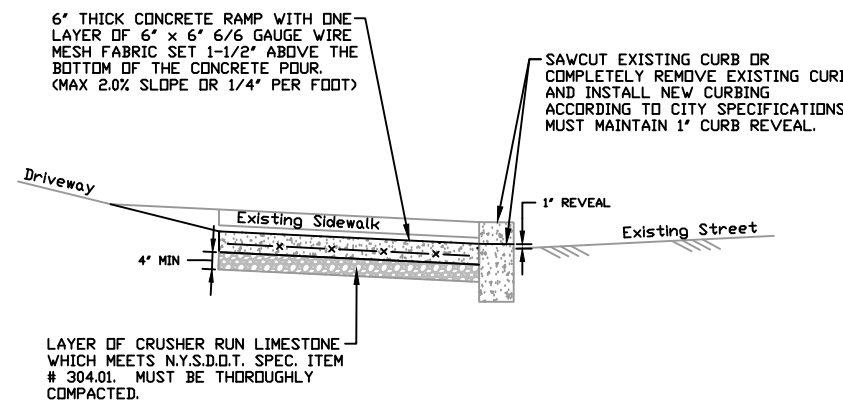

CROSS SECTION

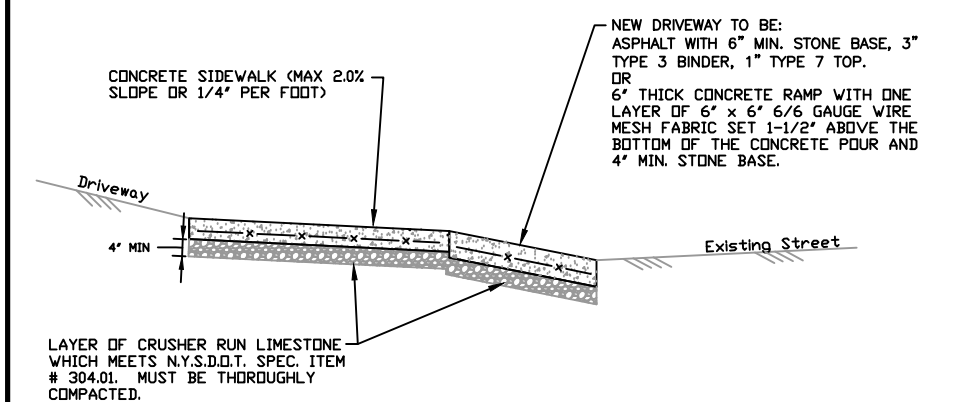

CROSS SECTION

DRIVEWAY ALONG STREET WITH CURB AND GRASS MEDIAN

DRIVEWAY ALONG STREET WITH CURB AND NO GRASS MEDIAN

DRIVEWAY ALONG STREET WITH NO CURB AND GRASS MEDIAN

**GENERAL NOTES:**

- 1). APPLY FOR A CURB CUT PERMIT (\$100 FEE) AT THE CITY OF WATERTOWN ENGINEERING DEPARTMENT PRIOR TO THE START OF CONSTRUCTION.
- 2). APPLY FOR A SIDEWALK PERMIT (NO FEE) AT THE CITY OF WATERTOWN ENGINEERING DEPARTMENT PRIOR TO DISTURBING EXISTING SIDEWALKS.
- 3). PERMITTEE SHALL PROVIDE VALID PROOF OF INSURANCE OF CONTRACTOR PERFORMING WORK PRIOR TO ISSUANCE OF PERMIT.
  - LIABILITY INSURANCE - ACCORD 25
  - WORKERS' COMPENSATION INSURANCE - NYS CERTIFICATE OF WORKERS' COMPENSATION INSURANCE OR C-105.2
  - WORKER'S COMPENSATION EXEMPTION - CE-200
- 4). PERMITTEE IS REQUIRED TO CONTACT DIG SAFELY NEW YORK AT (1-800-962-7962) OR ONLINE AT WWW.DIGSAFELYNEWYORK.COM TO REQUEST UTILITY MARKOUT PRIOR TO ANY EXCAVATION WORK.

**MAXIMUM DRIVEWAY SLOPE**

ROADWAY CLASSIFICATION	MINOR COMMERCIAL DRIVEWAY	RESIDENTIAL DRIVEWAY
URBAN	6%	8%

DESIGNED BY: JLW	REVISIONS:
DRAWN BY: JLW	07-07-2009 CURB CUT FEE
DATE: 05-18-2009	03-05-2018 CURB CUT FEE/MAX. SLOPE TABLE/TAPER
SCALE: N/A	06-23-2021 CURB CUT WIDTH
CHECKED BY: KH	
APPROVED BY: KH	

WARNING: It is a violation of Section 7209, Subdivision 2, of the New York State Education Law for any person other than a Licensed Professional Engineer to alter this map.

**CITY OF WATERTOWN  
ENGINEERING DEPARTMENT**

MUNICIPAL BUILDING, ROOM 305  
245 WASHINGTON STREET  
WATERTOWN, NEW YORK 13601

PHONE: 315-785-7740  
FAX: 315-785-7829

DETAIL SHEET

CURB CUT & DRIVEWAY  
DETAILS

SHEET NO.

1